

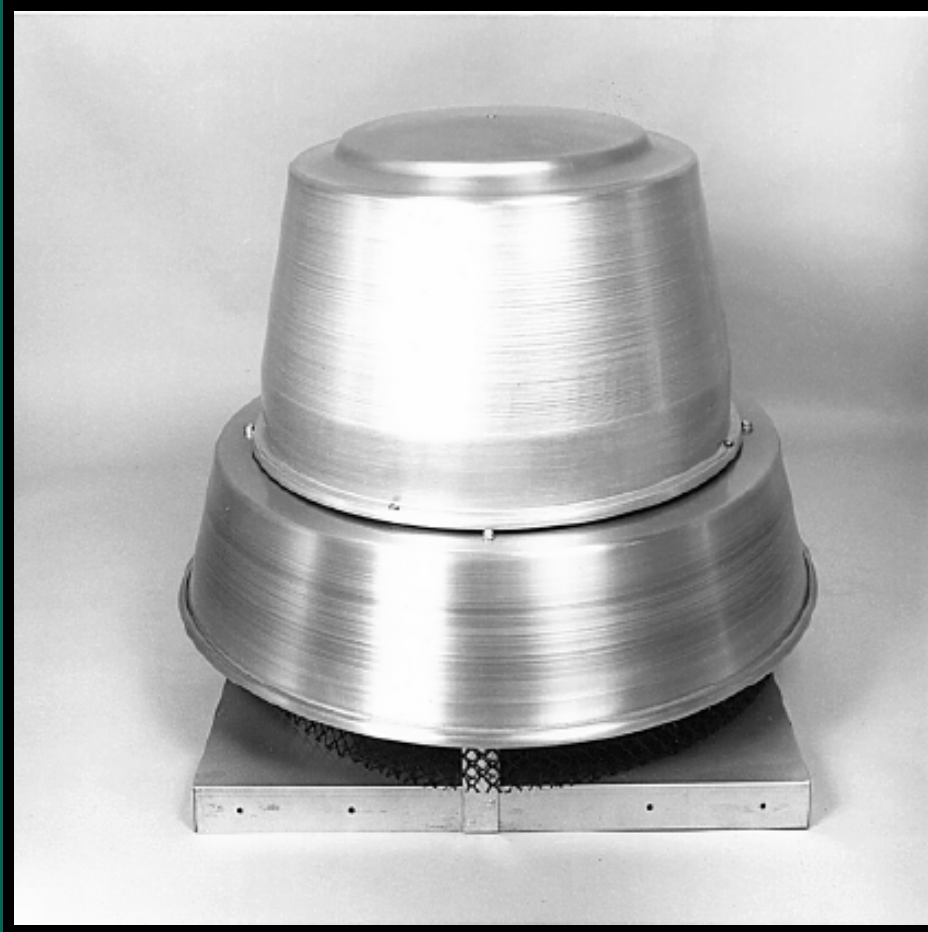

AMERICAN COOLAIR CORPORATION



# Centrifugal Power Roof Ventilators

TYPE CRBCA - BELT DRIVE

TYPE CRBA - BELT DRIVE

TYPE CRDA - DIRECT DRIVE

# TABLE OF CONTENTS

**CRBCA**



*Sizes 06 to 24  
Flow rates from  
185 to 10,328 CFM  
and 2" Static Pressure*

**CRBA**

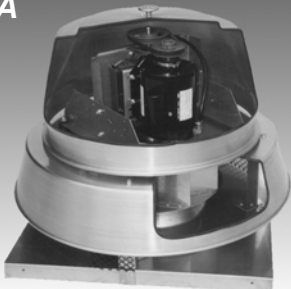

*Sizes 06 to 52  
Flow rates from  
185 to 43,962 CFM  
and 2" Static Pressure*

**CRDA**

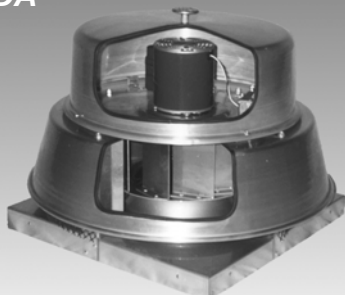

*Sizes 06 to 20  
Flow rates from  
162 to 5,730 CFM  
and 1" Static Pressure*

## BELT DRIVE FANS

### CRBCA and CRBA

- Dimensional Data ..... 3
- Fan Description - CRBCA ..... 4
- ILG's "C-Drive" ..... 5
- Fan Description - CRBA ..... 6
- Performance - 06-10 ..... 7
- Performance - 12 ..... 8
- Performance - 13 ..... 9
- Performance - 15 ..... 10
- Performance - 16 ..... 11
- Performance - 18 ..... 12
- Performance - 20 ..... 13
- Performance - 24 ..... 14
- Performance - 30 ..... 15
- Performance - 36 ..... 16
- Performance - 44 ..... 17
- Performance - 52 ..... 18

## DIRECT DRIVE FANS

### CRDA

- Dimensional Data ..... 3
- Fan Description ..... 19
- Performance - 06-10 ..... 20
- Performance - 12-13 ..... 21
- Performance - 15-20 ..... 22

- Installation & Accessories ..... 23
- Specification Checklist ..... 24

## STANDARD FEATURES

### CRBCA, CRBA and CRDA Units

**Weather-resistant aluminum motor compartment cover** removes easily for access to motor and drives.

**Out-of-airstream open motors** are isolated for protection from exhaust airstream.

**Aluminum centrifugal wheel** is non-overloading, backward inclined design with state-of-the-art computerized balance.

**Overlapping wheel and deep-spun venturi** minimize noise and air turbulence, increasing efficiency.

**Wheel balance weights** are permanently affixed to assure vibration-free operation.

**Wheel backplate fins** cool the motor compartment, extending motor life.

**Birdscreen** is 1/2" galvanized mesh

**AMCA Seal** assures certified rating of air and sound performance.

**UL Listed** for Standard 705.

## CRBCA and CRBA

**Factory-wired disconnect switch** is an available option.

**Belt drive with adjustable motor pulley** for flexibility to match operating requirements.

**Hinged motor bracket** with tensioning bolt(s) facilitates maintenance of belt tension.



## CRDA

**Factory-wired disconnect device** for standard motors.

**Direct-drive assembly** reduces maintenance and operating costs.

**Variable speed control** available on some models.

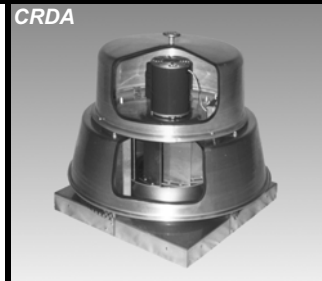

## CRBCA, CRBA and CRDA Ventilator, Roof Curb and Damper Dimensions

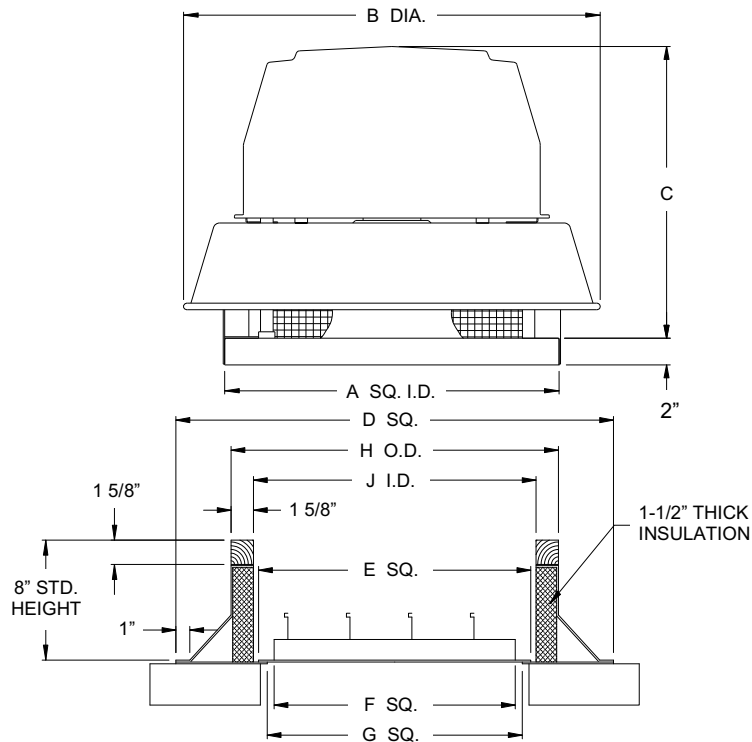

Unit	Ventilator Dimensions			Roof Curb and Damper Dimensions					
	A	B	C	D	E	F	G	H	J
CRBA & CRBCA 06, 08, 10	18	23 1/8	20 1/2	24 1/2	12 1/2	10	11 1/4	16 1/2	13 1/4
CRDA 06, 08, 10	18	23 1/8	12	24 1/2	12 1/2	10	11 1/4	16 1/2	13 1/4
CRBA & CRBCA 12, 13, 15 CRDA 12J17, 13K17 & 15L17	23	28 5/8	22 1/2	29 1/2	17 1/2	15	16 1/4	21 1/2	18 1/4
CRDA 12E10, 12J16, 13F11, 13J15, 15H10 & 15K15	23	28 5/8	16 1/2	29 1/2	17 1/2	15	16 1/4	21 1/2	18 1/4
CRBA, CRBCA & CRDA 16, 18, 20	30	35 1/2	24 5/8	36 1/2	24 1/2	22	23 1/4	28 1/2	25 1/4
CRBA & CRBCA 24	34	42 3/4	32 1/2	40 1/2	28 1/2	26	27 1/4	32 1/2	29 1/4
CRBA 30	40	50 1/4	36 3/4	46 1/2	34 1/2	32	33 1/4	38 1/2	35 1/4
CRBA 36	46	61 3/4	44 1/4	52 1/2	40 1/2	38	39 1/4	44 1/2	41 1/4
CRBA 44	56	71 1/4	49	62 1/2	50 1/2	48	49 1/4	54 1/2	51 1/4
CRBA 52	65	83 3/4	55 1/2	71 1/2	59 1/2	57	58 1/4	63 1/2	60 1/4

Dimensions in inches

# CRBCA

## Belt Drive Centrifugal Power Roof Ventilators

### Applications

The CRBCA units are quiet, dependable power roof ventilators recommended for a wide range of general exhaust applications where low and medium ranges of air volume and pressure are specified. Applications include virtually all types of light manufacturing, commercial and institutional buildings such as shopping centers, hospitals, schools, hotels, office and apartment buildings, warehouses, airports, bus terminals and many others.

CRBCA units are specified where a roof-mounted location is desired to eliminate interference with other equipment or activities in the building. They permit the direct upward venting of air. CRBCA units may be used with or without ducts.

The advantages of a CRBCA belt-drive over a direct-drive roof ventilator include quieter operation and adjustable performance to meet operating needs.

### Construction

CRBCA models feature a housing of durable spun aluminum for optimum weather protection. The overlapping deep-spun venturi minimizes air turbulence and increases efficiency.

The aluminum centrifugal wheel is a non-overloading, backward-inclined type, selected for low noise levels. Backplate fins draw cool air through the motor compartment. The wheel is secured to the machined aluminum "C-Drive" disc, and computer balanced on state-of-the-art equipment.

Neoprene vibration isolators to reduce noise and wear, and 1/2" galvanized mesh birdscreen are both standard.

### Drive Mechanism

The belt driven CRBCA utilizes a unique bearing/shaft arrangement that has been designated the "C-Drive". This "C-Drive" is patterned after American Coolair's unique static shaft drive design that has been in existence for over eighty years, serving the general ventilation markets with reliable propeller products. This type of drive uses a captured bearing arrangement inside a cast aluminum disc assembly locked to a short, large diameter shaft. The shaft is held stationary and the centrifugal wheel/disc assembly rotates on the shaft instead of the entire assembly rotating.

As a result of reduction of radial loading of the bearings, the calculated L10 bearing life exceeds 1,000,000 hours or an average bearing life of 5,000,000 hours. Most other manufacturers' turning shaft drive designs result in cataloged average bearing life of 150,000-200,000 hours. Additionally, the machined surface of the "C-Drive" provides a rigid backplate for the centrifugal wheel. Electrical connections on the end of the motor face upwards making field connections rapid and simple. This compact drive assembly provides more room in the motor compartment area and the single bolt, V-belt adjustment makes for a very serviceable unit.

### Motors

The standard motor for CRBCA models is open drip-proof construction, and located out of the airstream. Totally enclosed, energy efficient, two-speed and explosion-proof motors may also be available. All motor brands are recognized and serviced nationwide. Motor enclosure may affect UL Listing.



UL705 - E39944

Type CRBCA ventilators are Listed by Underwriters Laboratory Inc. to US and Canadian safety standards.



American Coolair Corporation, ILG Industries certifies that the Type CRBCA PRVs shown herein are licensed to bear the AMCA Seal. The ratings shown are based on tests and procedures performed in accordance with AMCA Publication 211 and AMCA Publication 311 and comply with the requirements of the AMCA Certified Ratings Program.

### Guide Specifications

Power Roof Ventilators shall be of the CRBCA centrifugal type as manufactured by ILG Industries of American Coolair Corporation (individual models to be listed in fan schedule). Units shall meet UL Standard 705 and shall bear the AMCA Certified Ratings Seal for air and sound performance. Base and venturi inlet shall be one piece heavy gauge spun aluminum or galvanized steel, with wheel and venturi overlapping for efficient operation. Motor compartment cover shall be heavy gauge aluminum construction and easily removable for access to motor and drive.

Drive construction shall be of the ILG "C-Drive" design consisting of static shaft/bearing arrangement mounted in a machined cast aluminum disc assembly. The disc assembly shall be mounted onto the backplate of the centrifugal wheel. The centrifugal wheel shall be heavy gauge aluminum with backward-inclined, non-overloading blades and be computer balanced.

Bearings shall have a calculated L10 bearing life in excess of 1,000,000 hours.

Motor shall be open drip-proof construction, NEMA design B with minimum service factor of 1.15. Adjustable motor pulley shall be provided to allow for field adjustment and system balance. Motor shall be mounted on a hinged steel mounting bracket, utilizing a belt tensioning bolt. Motor shall be mounted with the shaft down to allow easy access to the electrical wiring terminal board/circuit box.

(Mounted and wired disconnect switch, backdraft damper, epoxy coating, roof curb and other accessories shall be listed in the fan schedule.)

# ILG's "C-Drive"

Available Exclusively on CRBCA Units Sizes 06 - 24

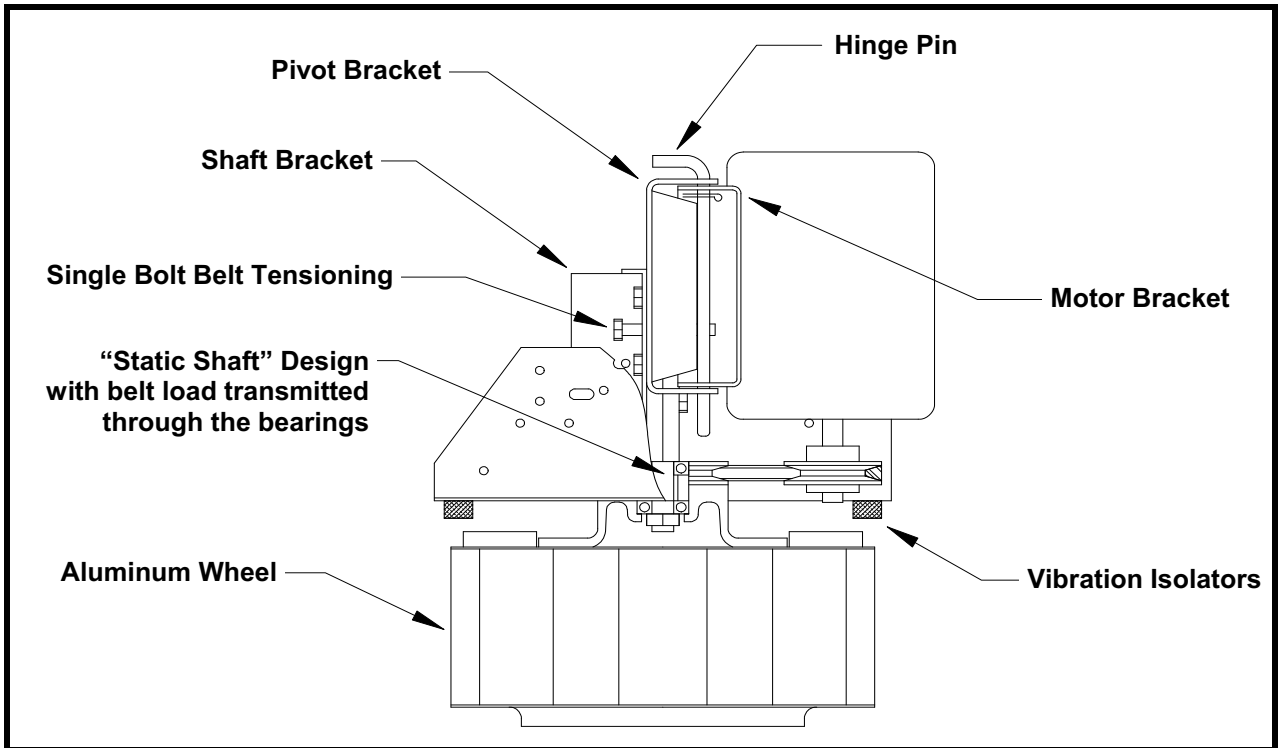

## ILG's "C-Drive" Wheel Assembly

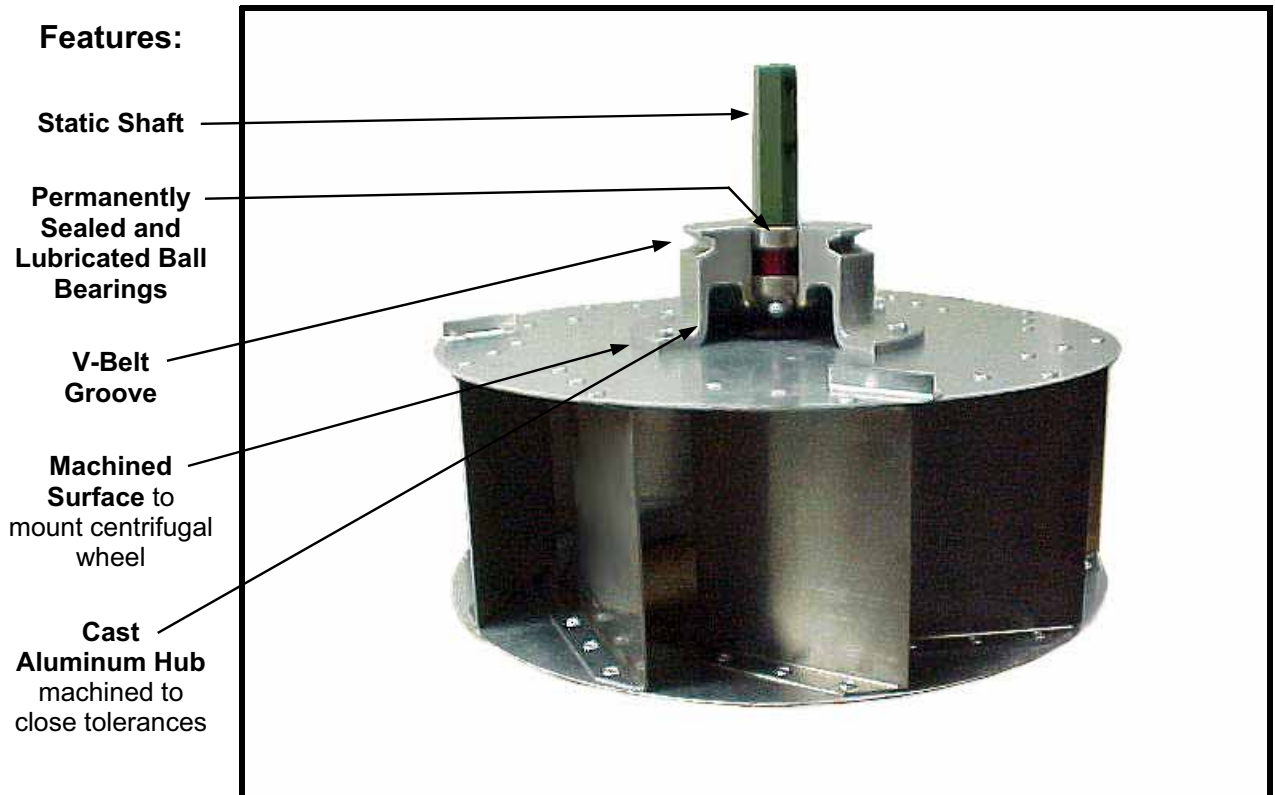

# CRBA

## Belt Drive Centrifugal Power Roof Ventilators

### Applications

The CRBA units are quiet, dependable power roof ventilators recommended for a wide range of general exhaust applications where low, medium and high ranges of air volume and pressure are specified. Applications include virtually all types of light manufacturing, commercial and institutional buildings such as shopping centers, hospitals, schools, hotels, office and apartment buildings, warehouses, airports, bus terminals and many others.

CRBA units are specified where a roof-mounted location is desired to eliminate interference with other equipment or activities in the building. They permit the direct upward venting of air. CRBA units may be used with or without ducts.

The advantages of a CRBA belt-drive over a direct-drive roof ventilator include quieter operation and adjustable performance to suit operating needs and availability of larger volume units.

### Construction

CRBA models feature a housing of durable spun aluminum for optimum weather protection. The overlapping deep-spun venturi minimizes air turbulence and increases efficiency.

The aluminum centrifugal wheel is a non-overloading, backward-inclined type, selected for low noise levels. Backplate fins draw cool air through the motor compartment. The wheel is secured to the machined aluminum hub, and computer balanced on state-of-the-art equipment.

Neoprene vibration isolators to reduce noise and wear, and 1/2" galvanized mesh birdscreen are both standard.

### Drive Mechanism

The belt driven CRBA utilizes a standard V-belt drive design with variable pitch cast iron pulley for adjusting fan speed. Drive shaft is turned, ground and polished. Motor support is adjustable for proper tensioning.

### Bearings

Heavy duty pillow-block ball bearings with cast iron housing are self-aligning and relubricable.

### Motors

The standard motor for CRBA models is open drip-proof construction, located out of the airstream. Totally enclosed, energy efficient, two-speed and explosion-proof motors may also be available. All motor brands are recognized and serviced nationwide. Motor enclosure may affect UL Listing.



UL705 - E39944

Type CRBA ventilators are Listed by Underwriters Laboratory Inc. to US and Canadian safety standards.



American Coolair Corporation, ILG Industries certifies that the Type CRBA PRVs shown herein are licensed to bear the AMCA Seal. The ratings shown are based on tests and procedures performed in accordance with AMCA Publication 211 and AMCA Publication 311 and comply with the requirements of the AMCA Certified Ratings Program.

### Guide Specifications

Power Roof Ventilators shall be of the CRBA centrifugal type as manufactured by ILG Industries of American Coolair Corporation (individual models to be listed in fan schedule). Units shall meet UL Standard 705 and shall bear the AMCA Certified Ratings Seal for air and sound performance. Base and venturi inlet shall be one piece heavy gauge spun aluminum or galvanized steel, with wheel and venturi overlapping for efficient operation. Motor compartment cover shall be heavy gauge aluminum construction and easily removable for access to motor and drive.

Drive mechanism shall incorporate a V-belt drive with cast iron motor pulley. Drive shaft shall be turned, ground and polished. The centrifugal wheel shall be heavy gauge aluminum with backward-inclined, non-overloading blades and be computer balanced.

Bearings shall be self-aligning and have fittings for relubrication.

Motor shall be open drip-proof construction, NEMA design B with minimum service factor of 1.15. Adjustable motor pulley shall be provided to allow for field adjustment and system balance. Motor shall be mounted on a hinged steel mounting bracket, utilizing belt tensioning bolt(s).

(Mounted and wired disconnect switch, backdraft damper, epoxy coating, roof curb and other accessories shall be listed in the fan schedule.)

# CRBCA / CRBA 06-10 Performance Data

CRBCA06 / CRBA06																			CFM at Static Pressure				RPM Range				RPM
0.00		.125		.250		.375		.500		.625		.750		1.00		1.25		1.50		Motor HP							
BHP	Sone	BHP	Sone	BHP	Sone	BHP	Sone	BHP	Sone	BHP	Sone	BHP	Sone	BHP	Sone	BHP	Sone	BHP	Sone	BHP	Sone	1/5	1/4 L	1/4 M	1/4 H		
279		206																				CRBCA ONLY					846
0.01	1.5	0.01	0.8																								1041
343		289		216																							1135
0.02	2.9	0.02	2.5	0.02	1.9																						1360
374		325		263		185																					1646
0.03	3.7	0.03	3.2	0.03	2.8	0.03	2.3																				1789
448		406		362		308		240																			2076
0.04	5.6	0.05	5.1	0.05	4.8	0.05	4.3	0.05	4.0																		2219
542		505		475		435		391		342																	
0.08	8.6	0.08	8.2	0.09	7.8	0.09	7.6	0.09	7.0	0.09	6.6																
589		555		526		495		455		414		366															
0.10	10.4	0.11	10.0	0.11	9.5	0.11	9.5	0.11	9.2	0.12	8.4	0.11	8.1														
684		653		628		603		575		541		506		429													
0.16	14.4	0.16	14.0	0.17	13.6	0.17	13.3	0.18	13.4	0.18	13.0	0.18	12.2	0.18	11.5												
731		702		677		655		631		602		569		503		419											
0.20	16.0	0.20	15.6	0.20	15.3	0.21	14.9	0.21	15.0	0.22	14.8	0.22	14.7	0.22	13.4	0.21	12.9										

CRBCA08 / CRBA08																			CFM at Static Pressure				RPM Range				RPM
0.00		.125		.250		.375		.500		.625		.750		1.00		1.25		1.50		Motor HP							
BHP	Sone	BHP	Sone	BHP	Sone	BHP	Sone	BHP	Sone	BHP	Sone	BHP	Sone	BHP	Sone	BHP	Sone	BHP	Sone	BHP	Sone	1/5	1/4 L	1/4 M	1/4 H		
367		290																				CRBCA ONLY					846
0.01	1.6	0.01	1.3																								1041
451		393		321																							1135
0.02	3.2	0.02	2.9	0.03	2.8																						1360
492		439		376		280																					1646
0.03	4.0	0.03	3.7	0.03	3.7	0.03	3.4																				1789
590		545		499		444		373																			2076
0.04	6.1	0.05	5.8	0.05	5.7	0.06	5.6	0.06	5.4																		2219
714		676		640		601		555		508		439															
0.08	9.4	0.08	9.3	0.09	8.6	0.10	8.7	0.10	8.6	0.10	8.5	0.10	8.4														
776		741		708		674		634		592		547															
0.10	11.4	0.11	11.3	0.12	10.5	0.12	10.6	0.13	10.4	0.13	10.4	0.13	10.3														
900		870		841		813		783		750		714		638		515											
0.16	15.6	0.16	15.2	0.17	15.3	0.18	14.4	0.19	14.6	0.19	14.5	0.20	14.3	0.21	14.4	0.20	14.1										
962		934		907		880		853		824		792		723		645		485									
0.19	17.8	0.20	17.3	0.21	17.7	0.22	16.5	0.23	16.4	0.23	16.5	0.24	16.3	0.25	16.4	0.26	16.2	0.23	15.9								

CRBCA10 / CRBA10																			CFM at Static Pressure				RPM Range				RPM
0.00		.125		.250		.375		.500		.625		.750		1.00		1.25		1.50		Motor HP							
BHP	Sone	BHP	Sone	BHP	Sone	BHP	Sone	BHP	Sone	BHP	Sone	BHP	Sone	BHP	Sone	BHP	Sone	BHP	Sone	BHP	Sone	1/5	1/4 L	1/4 M	1/4 H		
487		384																				CRBCA ONLY					846
0.01	2.1	0.02	1.6																								1041
599		519		422																							1135
0.03	3.7	0.03	3.3	0.03	3.0																						1360
653		579		497		383																					1646
0.03	4.5	0.04	4.1	0.04	4.0	0.04	3.1																				1789
783		720		660		586		494																			2076
0.06	6.5	0.07	6.2	0.07	6.0	0.08	5.8	0.08	4.8																		2219
948		895		845		795		734		667		586															
0.10	9.6	0.11	9.5	0.12	9.1	0.13	9.0	0.13	8.9	0.14	8.3	0.14	7.1														
1,030		982		935		890		839		782		719		540													
0.13	11.5	0.14	11.4	0.15	11.0	0.16	10.8	0.17	10.7	0.17	10.5	0.18	9.8	0.17	8.1												
1,195		1,153		1,112		1,073		1,035		992		943		839		703											
0.21	15.6	0.22	15.6	0.23	15.4	0.24	14.9	0.25	14.8	0.26	14.7	0.27	14.6	0.27	13.7	0.27	11.5										
1,278		1,238		1,200		1,162		1,126		1,090		1,047		955		847		703									
0.26	17.8	0.27	17.4	0.28	17.3	0.29	16.8	0.30	16.8	0.31	16.7	0.32	16.7	0.33	16.4	0.34	14.7	0.33	12.8								

Performance shown is for Type A: free inlet, free outlet. Performance ratings do not include the effects of appurtenances (accessories). Power rating (BHP) does not include transmission losses. Bearing losses are included. The sound ratings shown are loudness values in hemispherical sones at 1.5 m (5 ft) in a hemispherical free field calculated per AMCA Standard 301. Values shown are for Installation Type A: free inlet hemispherical sone levels.







# CRBCA15 / CRBA15 Performance Data

CFM at Static Pressure																			RPM Range					RPM	
0.00		.125		.250		.375		.500		.750		1.00		1.25		1.50		2.00		Motor HP					
BHP	Sone	BHP	Sone	BHP	Sone	BHP	Sone	BHP	Sone	BHP	Sone	BHP	Sone	BHP	Sone	BHP	Sone	BHP	Sone	1/4	1/3	1/2	3/4		1
1,754		1,687		1,578		1,459		1,328																	886
0.15	8.1	0.16	7.6	0.17	6.9	0.19	6.6	0.20	6.1																
1,845		1,785		1,682		1,562		1,471																	932
0.18	8.8	0.19	8.3	0.20	7.6	0.21	7.2	0.23	6.8																
1,938		1,884		1,787		1,675		1,586																	979
0.20	9.5	0.22	9.0	0.23	8.3	0.24	8.0	0.26	7.7																
2,031		1,982		1,891		1,793		1,691		1,399															1026
0.23	10.2	0.25	9.7	0.26	9.1	0.28	8.8	0.29	8.4	0.31	7.5														
2,122		2,077		1,992		1,902		1,794		1,580															1072
0.27	11.0	0.28	10.5	0.30	9.9	0.31	9.4	0.33	9.1	0.35	8.2														
2,215		2,173		2,095		2,009		1,906		1,737															1119
0.30	11.7	0.32	11.3	0.34	10.7	0.35	10.1	0.37	10.0	0.40	8.9														
2,308		2,269		2,197		2,115		2,024		1,864		1,526													1166
0.34	12.5	0.36	12.1	0.38	11.6	0.39	11.0	0.41	11.0	0.44	10.0	0.45	9.0												
2,399		2,362		2,297		2,217		2,135		1,971		1,728													1212
0.39	13.3	0.40	12.9	0.42	12.5	0.44	12.0	0.45	11.7	0.49	11.1	0.51	9.9												
2,492		2,457		2,399		2,321		2,245		2,076		1,899													1259
0.43	14.1	0.45	13.8	0.47	13.4	0.49	13.0	0.50	12.5	0.54	12.2	0.57	10.8												
2,583		2,550		2,497		2,422		2,349		2,179		2,044		1,713											1305
0.48	15.0	0.50	14.7	0.52	14.4	0.54	14.0	0.55	13.4	0.59	13.0	0.63	11.8	0.64	11.1										
2,676		2,645		2,597		2,525		2,455		2,289		2,166		1,920											1352
0.54	15.9	0.55	15.6	0.57	15.4	0.59	15.1	0.61	14.5	0.65	14.1	0.69	13.2	0.71	12.2										
2,769		2,739		2,695		2,628		2,559		2,406		2,275		2,093											1399
0.59	16.8	0.61	16.6	0.63	16.4	0.65	16.2	0.67	15.7	0.71	15.3	0.75	14.8	0.78	13.2										
2,860		2,831		2,791		2,728		2,661		2,520		2,378		2,244		1,951									1445
0.65	17.8	0.67	17.5	0.69	17.4	0.72	17.2	0.73	16.8	0.77	16.4	0.81	15.9	0.85	14.4	0.87	13.7								
2,953		2,925		2,888		2,830		2,764		2,633		2,483		2,373		2,146									1492
0.72	18.8	0.73	18.6	0.75	18.4	0.78	18.2	0.80	17.9	0.84	17.3	0.89	16.8	0.93	15.8	0.96	14.9								
3,046		3,019		2,985		2,932		2,868		2,742		2,590		2,487		2,315									1539
0.79	19.8	0.81	19.6	0.83	19.4	0.85	19.3	0.88	19.0	0.92	18.2	0.96	17.8	1.00	17.4	1.04	16.0								
3,137		3,111		3,079		3,030		2,968		2,847		2,702		2,590		2,464									1585
0.86	21	0.88	21	0.90	20	0.93	20	0.95	20	0.99	19.2	1.04	19.0	1.08	18.8	1.13	17.2								
3,230		3,205		3,174		3,130		3,071		2,953		2,819		2,695		2,594									1632
0.94	22	0.96	22	0.98	22	1.01	21	1.04	21	1.07	20	1.12	20	1.17	19.8	1.21	18.6								

Performance shown is for Type A: free inlet, free outlet. Performance ratings do not include the effects of appurtenances (accessories).  
 Power rating (BHP) does not include transmission losses. Bearing losses are included.  
 The sound ratings shown are loudness values in hemispherical sones at 1.5 m (5 ft) in a hemispherical free field calculated per AMCA Standard 301.  
 Values shown are for Installation Type A: free inlet hemispherical sone levels.

# CRBCA16 / CRBA16 Performance Data

CFM at Static Pressure																		RPM Range Motor HP						RPM			
0.00		.125		.250		.375		.500		.750		1.00		1.25		1.50		2.00		1/4	1/3	1/2	3/4		1	1 1/4	
BHP	Sone	BHP	Sone	BHP	Sone	BHP	Sone	BHP	Sone	BHP	Sone	BHP	Sone	BHP	Sone	BHP	Sone	BHP	Sone	BHP	Sone						
2,170		2,034		1,862		1,683		1,427																			734
0.15	7.3	0.17	6.4	0.19	5.9	0.20	5.4	0.20	4.8																		
2,279		2,152		1,992		1,823		1,620																			771
0.18	7.8	0.20	7.0	0.21	6.6	0.23	6.1	0.23	5.6																		
2,385		2,265		2,116		1,954		1,780																			807
0.20	8.5	0.22	7.8	0.24	7.3	0.26	6.8	0.27	6.4																		
2,495		2,381		2,242		2,086		1,930																			844
0.23	9.2	0.26	8.6	0.28	8.1	0.29	7.7	0.30	7.2																		
2,604		2,496		2,367		2,217		2,070		1,634																	881
0.26	10.0	0.29	9.5	0.31	8.9	0.33	8.5	0.34	8.1	0.33	7.0																
2,713		2,610		2,489		2,347		2,206		1,853																	918
0.30	10.8	0.32	10.4	0.35	9.7	0.37	9.5	0.38	8.9	0.39	7.9																
2,820		2,721		2,607		2,473		2,336		2,029																	954
0.34	11.8	0.36	11.3	0.39	10.6	0.41	10.4	0.42	9.8	0.44	9.0																
2,929		2,834		2,727		2,601		2,467		2,191		1,659															991
0.38	12.7	0.40	12.3	0.43	11.6	0.45	11.3	0.47	10.9	0.49	10.1	0.45	9.0														
3,039		2,947		2,845		2,727		2,598		2,341		1,958															1028
0.42	13.6	0.45	13.4	0.47	12.5	0.50	12.2	0.52	11.9	0.54	11.1	0.54	10.0														
3,145		3,057		2,960		2,848		2,725		2,480		2,161															1064
0.47	14.7	0.50	14.5	0.52	13.6	0.55	13.2	0.57	13.0	0.60	12.1	0.61	11.1														
3,254		3,170		3,077		2,972		2,854		2,617		2,340															1101
0.52	15.7	0.55	15.6	0.58	14.8	0.60	14.2	0.62	14.1	0.66	13.1	0.68	12.4														
3,364		3,282		3,193		3,093		2,982		2,751		2,503		2,114													1138
0.57	16.8	0.60	16.7	0.63	16.0	0.66	15.3	0.68	15.2	0.72	14.2	0.75	13.7	0.72	12.5												
3,470		3,391		3,306		3,211		3,105		2,880		2,651		2,333													1174
0.63	17.9	0.66	17.9	0.69	17.2	0.72	16.3	0.74	16.2	0.79	15.3	0.81	14.8	0.81	13.7												
3,579		3,503		3,421		3,331		3,230		3,012		2,796		2,522													1211
0.69	18.9	0.72	19.0	0.75	18.3	0.78	17.4	0.81	17.2	0.85	16.4	0.89	15.8	0.90	14.9												
3,689		3,615		3,536		3,449		3,354		3,143		2,936		2,693		2,325											1248
0.75	19.7	0.79	19.8	0.82	19.2	0.85	18.3	0.88	17.9	0.93	17.4	0.96	16.5	0.98	16.0	0.95	14.8										
3,798		3,727		3,650		3,567		3,476		3,273		3,072		2,852		2,550											1285
0.82	21	0.86	21	0.89	20	0.92	19.2	0.95	18.7	1.01	18.4	1.04	17.3	1.07	17.0	1.06	15.7										
3,905		3,835		3,761		3,681		3,595		3,399		3,202		2,998		2,736											1321
0.89	21	0.93	21	0.96	21	1.00	20	1.03	19.5	1.08	19.3	1.13	18.1	1.16	17.8	1.17	16.9										
4,073		4,007		3,936		3,861		3,780		3,597		3,406		3,218		2,998											1378
1.01	23	1.05	23	1.09	22	1.12	22	1.16	21	1.22	21	1.26	19.6	1.30	19.0	1.33	18.5										
4,182		4,118		4,050		3,977		3,899		3,725		3,537		3,355		3,154		2,484									1415
1.10	23	1.14	24	1.17	23	1.21	23	1.24	22	1.31	21	1.36	21	1.40	19.8	1.43	19.5	1.35	17.7								
4,292		4,229		4,163		4,093		4,018		3,851		3,668		3,490		3,303		2,757									1452
1.19	24	1.23	24	1.26	24	1.30	23	1.34	23	1.40	22	1.46	22	1.50	21	1.54	21	1.51	18.6								
4,401		4,340		4,276		4,208		4,136		3,975		3,798		3,623		3,447		2,973									1489
1.28	25	1.32	25	1.36	25	1.40	24	1.43	24	1.50	23	1.56	23	1.61	22	1.65	21	1.66	19.6								

Performance shown is for Type A: free inlet, free outlet. Performance ratings do not include the effects of appurtenances (accessories). Power rating (BHP) does not include transmission losses. Bearing losses are included. The sound ratings shown are loudness values in hemispherical sones at 1.5 m (5 ft) in a hemispherical free field calculated per AMCA Standard 301. Values shown are for Installation Type A: free inlet hemispherical sone levels.







# CRBA30 Performance Data

CFM at Static Pressure																			RPM Range						RPM		
0.00		.125		.250		.375		.500		.750		1.00		1.25		1.50		2.00		Motor HP							
BHP	Sone	BHP	Sone	BHP	Sone	BHP	Sone	BHP	Sone	BHP	Sone	BHP	Sone	BHP	Sone	BHP	Sone	BHP	Sone	1/2	3/4	1	1 1/2	2		3	5
6,380		5,549		4,719																							400
0.33	6.0	0.34	5.3	0.35	4.8																						
7,034		6,283		5,505		4,588																					441
0.44	7.1	0.46	6.5	0.47	5.9	0.47	5.7																				
7,528		6,828		6,097		5,413		3,187																			472
0.54	8.1	0.56	7.4	0.57	6.9	0.58	6.6	0.50	6.5																		
8,325		7,693		7,042		6,398		5,696																			522
0.73	10.0	0.75	9.2	0.76	8.7	0.78	8.4	0.78	8.2																		
8,868		8,274		7,671		7,046		6,480																			556
0.88	11.5	0.90	10.7	0.92	10.1	0.93	9.7	0.95	9.5																		
9,474		8,918		8,358		7,771		7,221																			594
1.08	13.3	1.10	12.4	1.12	11.8	1.13	11.4	1.15	11.1																		
9,888		9,356		8,821		8,263		7,716		6,348																	620
1.22	14.5	1.25	13.7	1.27	13.1	1.28	12.6	1.30	12.3	1.30	12.0																
10,335		9,825		9,315		8,787		8,251		7,203																	648
1.40	15.6	1.42	14.8	1.44	14.1	1.46	13.6	1.48	13.3	1.50	13.0																
10,734		10,243		9,752		9,249		8,727		7,771																	673
1.57	16.6	1.59	15.8	1.61	15.1	1.63	14.6	1.65	14.2	1.68	13.9																
11,244		10,776		10,307		9,831		9,335		8,412		6,811															705
1.80	17.9	1.82	17.0	1.85	16.4	1.87	15.8	1.88	15.5	1.93	15.0	1.87	14.9														
11,802		11,356		10,910		10,460		9,993		9,082		8,104															740
2.08	19.3	2.11	18.4	2.13	17.8	2.16	17.2	2.17	16.8	2.22	16.3	2.23	16.1														
12,281		11,852		11,423		10,992		10,549		9,654		8,822		6,474													770
2.35	21	2.37	19.8	2.40	19.0	2.43	18.4	2.44	18.0	2.49	17.4	2.52	17.2	2.33	17.1												
12,807		12,396		11,985		11,572		11,152		10,284		9,497		8,296													803
2.66	22	2.68	21	2.72	21	2.75	19.8	2.76	19.3	2.81	18.7	2.86	18.4	2.82	18.3												
13,238		12,840		12,442		12,044		11,640		10,798		10,020		9,132													830
2.94	23	2.96	22	2.99	22	3.03	21	3.05	21	3.09	19.8	3.15	19.4	3.15	19.3												
13,668		13,283		12,898		12,512		12,123		11,311		10,534		9,777		7,950											857
3.23	25	3.26	24	3.29	23	3.33	22	3.35	22	3.39	21	3.45	21	3.48	20	3.33	20										
14,354		13,987		13,620		13,254		12,885		12,120		11,355		10,662		9,751											900
3.75	27	3.77	26	3.81	25	3.84	24	3.87	24	3.91	23	3.97	22	4.02	22	4.01	22										
14,992		14,641		14,290		13,939		13,586		12,863		12,118		11,432		10,738											940
4.27	29	4.29	28	4.33	27	4.37	26	4.40	26	4.44	25	4.49	24	4.56	24	4.59	24										
15,710		15,374		15,039		14,704		14,369		13,686		12,974		12,289		11,662		8,885									985
4.91	31	4.94	30	4.97	30	5.01	29	5.05	28	5.10	27	5.14	27	5.22	26	5.27	26	5.00	26								
16,156		15,830		15,504		15,179		14,853		14,192		13,503		12,824		12,204		10,388									1013
5.34	33	5.37	32	5.40	31	5.45	31	5.49	30	5.54	29	5.58	28	5.65	28	5.72	27	5.65	27								

Performance shown is for Type A: free inlet, free outlet. Performance ratings do not include the effects of appurtenances (accessories). Power rating (BHP) does not include transmission losses. Bearing losses are included. The sound ratings shown are loudness values in hemispherical sones at 1.5 m (5 ft) in a hemispherical free field calculated per AMCA Standard 301. Values shown are for Installation Type A: free inlet hemispherical sone levels.







# CRBA52 Performance Data

CFM at Static Pressure																	RPM Range Motor HP						RPM	
0.00		.125		.250		.375		.500		.750		1.00		1.25		1.50		1 ½	2	3	5	7 ½		10
BHP	Sone	BHP	Sone	BHP	Sone	BHP	Sone	BHP	Sone	BHP	Sone	BHP	Sone	BHP	Sone	BHP	Sone							
17,671		14,598		9,727																				205
0.71	4.9	0.75	4.2	0.69	3.9																			
19,395		16,562		13,111																				225
0.93	5.9	0.98	5.3	0.97	4.8																			
21,119		18,509		15,810		10,531																		245
1.21	7.2	1.26	6.4	1.27	6.1	1.15	5.8																	
22,843		20,449		18,093		14,425																		265
1.53	8.6	1.59	7.7	1.62	7.3	1.56	7.0																	
24,567		22,371		20,154		17,404		12,676																285
1.90	10.2	1.96	9.1	2.01	8.7	1.99	8.5	1.83	8.0															
26,032		23,984		21,839		19,601		15,994																302
2.26	11.7	2.33	10.6	2.38	10.1	2.39	9.9	2.29	9.3															
28,446		26,602		24,570		22,735		20,222																330
2.95	14.5	3.02	13.1	3.09	12.5	3.12	12.3	3.09	12.1															
29,997		28,264		26,323		24,578		22,545		15,272														348
3.46	16.3	3.54	15.0	3.61	14.2	3.65	14.0	3.65	13.9	3.31	12.6													
31,463		29,820		27,974		26,267		24,519		18,742														365
3.99	18.2	4.07	16.8	4.15	16.0	4.21	15.7	4.23	15.6	4.01	14.4													
32,669		31,096		29,328		27,641		26,036		21,078														379
4.47	19.8	4.55	18.4	4.63	17.5	4.70	17.1	4.73	17.0	4.58	16.1													
34,307		32,816		31,154		29,492		27,994		23,907		16,647												398
5.17	22	5.26	21	5.35	19.7	5.42	19.1	5.47	19.0	5.39	18.4	4.86	17.0											
36,204		34,799		33,248		31,633		30,187		26,844		21,377												420
6.08	25	6.18	23	6.27	22	6.35	21	6.41	21	6.41	20	6.09	19.0											
38,272		36,949		35,507		33,967		32,538		29,691		25,323		18,344										444
7.18	27	7.28	25	7.38	24	7.47	23	7.54	23	7.61	22	7.40	21	6.72	20									
40,686		39,448		38,112		36,673		35,265		32,707		29,316		24,335		15,163								472
8.63	30	8.74	28	8.84	27	8.94	26	9.03	25	9.14	25	9.05	24	8.68	23	7.26	22							
42,669		41,492		40,233		38,877		37,503		35,045		32,229		28,097		22,273								495
9.95	32	10.07	30	10.18	29	10.28	28	10.38	28	10.51	27	10.52	27	10.25	26	9.60	24							
43,962		42,821		41,607		40,304		38,961		36,537		33,982		30,319		25,373								510
10.89	34	11.00	32	11.12	31	11.23	30	11.33	29	11.48	28	11.52	28	11.32	28	10.84	26							

Performance shown is for Type A: free inlet, free outlet. Performance ratings do not include the effects of appurtenances (accessories). Power rating (BHP) does not include transmission losses. Bearing losses are included. The sound ratings shown are loudness values in hemispherical sones at 1.5 m (5 ft) in a hemispherical free field calculated per AMCA Standard 301. Values shown are for Installation Type A: free inlet hemispherical sone levels.

# CRDA

## Belt Drive Centrifugal Power Roof Ventilators

### Applications

The CRDA units are quiet, dependable power roof ventilators recommended for a wide range of general exhaust applications where low and medium ranges of air volume and pressure are specified. Applications include virtually all types of light manufacturing, commercial and institutional buildings such as shopping centers, hospitals, schools, hotels, office and apartment buildings, warehouses, airports, bus terminals and many others.

CRDA units are specified where a roof-mounted location is desired to eliminate interference with other equipment or activities in the building. They permit the direct upward venting of air. CRDA units may be used with or without ducts.

The advantages of a CRDA direct-drive over a belt-drive roof ventilator include lower maintenance requirements, reduced risk of lower performance levels as a result of loosened belts, and lower operating costs.

### Construction

CRDA models feature a housing of durable spun aluminum for optimum weather protection. The overlapping deep-spun venturi minimizes air turbulence and increases efficiency.

The aluminum centrifugal wheel is a non-overloading, backward-inclined type, selected for low noise levels. Backplate fins draw cool air through the motor compartment.

The wheel is secured to the machined aluminum hub, and computer balanced on state-of-the-art equipment. The hub features a line bore, which eliminates the need for bushings. Neoprene vibration isolators to reduce noise and wear, 1/2" galvanized mesh birdscreen and factory wired disconnect device are all standard features.

### Drive Mechanism

CRDA models have all the advantages of a direct drive assembly. There are no belts, bearings or pulleys to consume power or require maintenance.

### Motors

The standard motor for most CRDA models is open drip-proof construction and located out of the airstream. Totally enclosed, energy efficient, two-speed and explosion-proof motors may also be available. All motor brands are recognized and serviced nationwide. Motor enclosure may affect UL Listing.



UL705 - E39944

Type CRDA ventilators are Listed by Underwriters Laboratory Inc. to US and Canadian safety standards.



American Coolair Corporation, ILG Industries certifies that the Type CRDA PRVs shown herein are licensed to bear the AMCA Seal. The ratings shown are based on tests and procedures performed in accordance with AMCA Publication 211 and AMCA Publication 311 and comply with the requirements of the AMCA Certified Ratings Program.

### Guide Specifications

Power Roof Ventilators shall be of the CRDA centrifugal type as manufactured by ILG Industries of American Coolair Corporation (individual models to be listed in fan schedule). Units shall meet UL Standard 705 and shall bear the AMCA Certified Ratings Seal for air and sound performance. Base and venturi inlet shall be one piece heavy gauge spun galvanized steel, with wheel and venturi overlapping for efficient operation. Motor compartment cover shall be heavy gauge spun aluminum construction and easily removable for access to motor and drive.

Drive mechanism shall be of the direct-drive design. The line bore hub shall be mounted onto the backplate of the centrifugal wheel. The centrifugal wheel shall be heavy gauge aluminum with backward-inclined, non-overloading blades and be computer balanced.

Motor shall be open construction, NEMA design B. Optional variable speed control on some models allows for field adjustment and system balance. Motor shall be mounted with the shaft down to allow easy access to the electrical terminal board/circuit box.

Backdraft damper, epoxy coating, roof curb and other accessories shall be listed in the fan schedule.)

# CRDA06 - CRDA10 Performance Data

CRDA06 CFM at Static Pressure																RPM RANGE OF SELECTED MODELS			RPM	
0.00		.125		.250		.375		.500		.625		.750		1.00		CRDA06A11	CRDA06C16	CRDA06E16		
BHP	Sone	BHP	Sone	BHP	Sone	BHP	Sone	BHP	Sone	BHP	Sone	BHP	Sone	BHP	Sone	BHP	Sone	1/25 HP	1/13 HP	1/10 HP
183																				550
0.01	0.5																			
266		187																		800
0.01	1.5	0.01	1.1																	
316		254		162																950
0.02	2.9	0.02	2.4	0.02	2.1															
366		315		250		163														1100
0.02	4.4	0.03	4.0	0.03	3.7	0.02	3.3													
416		371		318		252		174												1250
0.03	6.3	0.04	5.8	0.04	5.4	0.04	5.1	0.03	4.8											
465		424		383		331		262												1400
0.05	8.1	0.05	7.6	0.05	7.2	0.06	7.0	0.05	6.6											
532		494		462		420		375		316										1600
0.07	10.8	0.08	10.3	0.08	9.8	0.08	9.4	0.08	9.1	0.08	8.7									
548		512		481		442		398		348				283						1650
0.08	11.5	0.08	11.1	0.09	10.5	0.09	10.0	0.09	9.8	0.09	9.4	0.09	9.0							

CRDA08 CFM at Static Pressure																RPM RANGE OF SELECTED MODELS			RPM	
0.00		.125		.250		.375		.500		.625		.750		1.00		CRDA08A11	CRDA08C15	CRDA08E16		
BHP	Sone	BHP	Sone	BHP	Sone	BHP	Sone	BHP	Sone	BHP	Sone	BHP	Sone	BHP	Sone	BHP	Sone	1/25 HP	1/13 HP	1/10 HP
239																				550
0.01	0.5																			
347		267																		800
0.01	1.4	0.01	1.2																	
412		349		256																950
0.02	2.7	0.02	2.4	0.02	2.3															
477		426		360		224														1100
0.02	4.2	0.03	3.9	0.03	3.8	0.03	3.7													
542		497		444		381		205												1250
0.03	5.9	0.04	5.6	0.04	5.6	0.05	5.4	0.04	5.2											
607		566		524		471		409		237										1400
0.05	7.6	0.05	7.3	0.06	7.2	0.06	7.1	0.06	7.0	0.05	6.8									
672		634		599		554		505		446				303						1550
0.07	9.4	0.07	9.1	0.08	8.9	0.08	8.9	0.09	8.8	0.09	8.6	0.07	8.4							
694		657		624		581		534		482				393						1600
0.07	10.0	0.08	9.8	0.08	9.6	0.09	9.5	0.09	9.4	0.10	9.3	0.09	9.1							

CRDA10 CFM at Static Pressure																RPM RANGE OF SELECTED MODELS			RPM	
0.00		.125		.250		.375		.500		.625		.750		1.00		CRDA10A11	CRDA10C15	CRDA10E15		
BHP	Sone	BHP	Sone	BHP	Sone	BHP	Sone	BHP	Sone	BHP	Sone	BHP	Sone	BHP	Sone	BHP	Sone	1/25 HP	1/13 HP	1/10 HP
316																				550
0.01	0.2																			
460		350																		800
0.01	1.9	0.02	1.3																	
546		459		342																950
0.02	3.2	0.02	2.8	0.03	2.3															
633		557		471		342														1100
0.03	4.8	0.04	4.4	0.04	3.9	0.04	3.5													
719		651		582		498		357												1250
0.05	6.6	0.05	6.3	0.06	5.9	0.06	5.4	0.06	5.0											
805		744		687		617		537		405										1400
0.06	8.0	0.07	7.8	0.08	7.5	0.08	7.1	0.08	6.7	0.08	6.3									
863		805		752		691		621		538				226						1500
0.08	9.2	0.09	9.0	0.09	8.7	0.10	8.3	0.10	7.9	0.10	7.5	0.06	7.2							
891		836		784		727		661		586				474						1550
0.09	9.8	0.10	9.6	0.10	9.3	0.11	8.9	0.11	8.5	0.11	8.1	0.11	7.7							

Performance shown is for Type A: free inlet, free outlet. Performance ratings do not include the effects of appurtenances (accessories).  
 The sound ratings shown are loudness values in hemispherical sones at 1.5 m (5 ft) in a hemispherical free field calculated per AMCA Standard 301.  
 Values shown are for Installation Type A: free inlet hemispherical sone levels.  
 AMCA Certified Ratings apply to the CRDA Roof Ventilator constant speed fans and not variable speed fans.

# CRDA12 - CRDA13 Performance Data

CRDA12 CFM at Static Pressure																RPM RANGE OF SELECTED MODELS			RPM
0.00		.125		.250		.375		.500		.625		.750		1.00		CRDA12E10	CRDA12J16	CRDA12J17*	
BHP	Sone	BHP	Sone	BHP	Sone	BHP	Sone	BHP	Sone	BHP	Sone	BHP	Sone	BHP	Sone	1/8 HP	1/2 HP	1/2 HP	
623		442																	550
0.01	1.3	0.02	0.7																
736		593																	650
0.02	2.3	0.03	1.7																
850		729		577															750
0.03	3.3	0.04	2.7	0.04	2.5														
963		856		737		557													850
0.05	4.4	0.05	3.8	0.06	3.6	0.06	3.4												
1,076		981		882		762		530											950
0.06	5.4	0.07	5.0	0.08	4.8	0.08	4.7	0.07	4.5										
1,161		1,074		984		879		747											1025
0.08	6.4	0.09	6.0	0.10	5.8	0.10	5.7	0.10	5.5										
1,303		1,225		1,145		1,062		964		843		566							1150
0.11	8.1	0.12	7.7	0.14	7.4	0.14	7.4	0.15	7.3	0.15	7.1	0.12	7.0						
1,473		1,405		1,334		1,264		1,186		1,100		1,002							1300
0.16	10.5	0.18	10.1	0.19	9.8	0.20	9.7	0.21	9.6	0.22	9.6	0.22	9.5						
1,643		1,582		1,519		1,455		1,392		1,322		1,244		1,057					1450
0.23	13.1	0.24	12.8	0.26	12.5	0.27	12.3	0.28	12.2	0.29	12.2	0.30	12.1	0.30	11.9				
1,813		1,758		1,701		1,643		1,586		1,529		1,464		1,322					1600
0.30	15.5	0.32	15.2	0.34	14.9	0.35	14.7	0.37	14.5	0.38	14.4	0.39	14.3	0.40	14.2				
1,915		1,863		1,809		1,755		1,700		1,647		1,590		1,460					1690
0.36	17.1	0.38	16.8	0.39	16.5	0.41	16.2	0.43	16.1	0.44	16.0	0.45	15.9	0.47	15.7				
1,955		1,904		1,851		1,798		1,744		1,692		1,637		1,512					1725
0.38	17.7	0.40	17.4	0.42	17.1	0.43	16.9	0.45	16.7	0.46	16.6	0.47	16.5	0.50	16.3				

CRDA13 CFM at Static Pressure																RPM RANGE OF SELECTED MODELS			RPM
0.00		.125		.250		.375		.500		.625		.750		1.00		CRDA13F11	CRDA13J15	CRDA13K17*	
BHP	Sone	BHP	Sone	BHP	Sone	BHP	Sone	BHP	Sone	BHP	Sone	BHP	Sone	BHP	Sone	1/5 HP	1/2 HP	3/4 HP	
833		635																	550
0.02	2.0	0.03	1.3																
1,023		869		674															675
0.04	3.6	0.04	2.8	0.05	2.3														
1,212		1,087		941		759													800
0.06	5.0	0.07	4.4	0.08	3.9	0.08	3.6												
1,363		1,255		1,130		991		812											900
0.08	6.2	0.10	5.9	0.11	5.4	0.11	5.0	0.11	4.7										
1,515		1,420		1,310		1,192		1,058		890									1000
0.12	7.7	0.13	7.4	0.14	7.0	0.15	6.6	0.15	6.2	0.15	6.0								
1,704		1,622		1,527		1,426		1,319		1,199		1,057							1125
0.17	9.8	0.18	9.5	0.19	9.2	0.20	8.8	0.21	8.4	0.22	8.1	0.21	7.8						
1,894		1,821		1,737		1,649		1,556		1,459		1,352		1,082					1250
0.23	12.2	0.25	12.0	0.26	11.7	0.27	11.4	0.28	11.0	0.29	10.6	0.30	10.3	0.29	9.7				
2,045		1,978		1,903		1,822		1,739		1,651		1,560		1,348					1350
0.29	14.3	0.31	14.1	0.32	13.9	0.34	13.5	0.35	13.2	0.36	12.9	0.37	12.5	0.37	11.9				
2,235		2,174		2,107		2,034		1,960		1,882		1,801		1,629					1475
0.37	16.6	0.39	16.4	0.42	16.2	0.43	15.9	0.44	15.6	0.46	15.3	0.47	15.0	0.48	14.5				
2,386		2,330		2,268		2,201		2,132		2,061		1,987		1,834					1575
0.45	18.3	0.48	18.2	0.50	18.1	0.52	17.8	0.53	17.5	0.54	17.1	0.56	16.8	0.59	16.3				
2,651		2,601		2,547		2,488		2,427		2,365		2,301		2,168					1750
0.62	22	0.65	22	0.67	22	0.70	22	0.72	21	0.73	21	0.74	21	0.78	20				

Performance shown is for Type A: free inlet, free outlet. Performance ratings do not include the effects of appurtenances (accessories).  
 The sound ratings shown are loudness values in hemispherical sones at 1.5 m (5 ft) in a hemispherical free field calculated per AMCA Standard 301.  
 Values shown are for Installation Type A: free inlet hemispherical sone levels.  
 \* - These models are not compatible with variable speed control.  
 AMCA Certified Ratings apply to the CRDA Roof Ventilator constant speed fans and not variable speed fans.

# CRDA15 - CRDA 20 Performance Data

CRDA15																CFM at Static Pressure			RPM RANGE OF SELECTED MODELS			RPM
0.00		.125		.250		.375		.500		.625		.750		1.00		CRDA15H11	CRDA15K15	CRDA15L17*				
BHP	Sone	BHP	Sone	BHP	Sone	BHP	Sone	BHP	Sone	BHP	Sone	BHP	Sone	BHP	Sone	1/3 HP	3/4 HP	1 HP				
1,089		930																	550			
0.04	2.4	0.04	1.9																650			
		1,169		1,015															750			
0.06	3.9	0.07	3.2	0.08	3.1														850			
1,484		1,391		1,250		1,088													950			
0.09	5.2	0.10	4.5	0.11	4.3	0.12	4.3												1100			
1,682		1,609		1,493		1,378		1,194											1150			
0.13	6.8	0.15	6.2	0.16	5.9	0.17	5.8	0.18	5.7										1250			
1,880		1,824		1,722		1,604		1,517		1,334									1350			
0.19	8.6	0.20	8.0	0.21	7.6	0.23	7.5	0.24	7.3	0.25	7.2								1425			
2,177		2,134		2,053		1,966		1,860		1,785		1,677							1550			
0.29	11.9	0.30	11.4	0.32	10.9	0.33	10.7	0.35	10.5	0.36	10.4	0.38	10.2						1725			
2,276		2,237		2,163		2,079		1,984		1,897		1,824										
0.33	13.1	0.34	12.6	0.36	12.2	0.38	11.9	0.39	11.7	0.41	11.6	0.43	11.4									
2,474		2,439		2,379		2,301		2,224		2,128		2,056		1,868								
0.42	15.6	0.44	15.1	0.46	14.7	0.48	14.4	0.49	14.2	0.51	14.1	0.53	13.9	0.56	13.5							
2,672		2,641		2,593		2,521		2,450		2,375		2,284		2,161								
0.53	17.8	0.55	17.4	0.57	17.0	0.59	16.8	0.61	16.5	0.63	16.4	0.65	16.2	0.68	15.8							
2,820		2,791		2,750		2,685		2,617		2,549		2,471		2,333								
0.63	20	0.64	19.2	0.66	18.9	0.69	18.6	0.71	18.4	0.72	18.1	0.75	17.7	0.79	17.2							
2,969		2,941		2,904		2,847		2,782		2,718		2,652		2,501								
0.73	21	0.75	21	0.77	20	0.79	20	0.82	20	0.83	20	0.85	19.3	0.90	18.8							
3,414		3,391		3,363		3,325		3,273		3,216		3,160		3,046								
1.11	26	1.13	26	1.15	25	1.18	25	1.21	24	1.24	24	1.25	24	1.30	24							

CRDA16																CFM at Static Pressure			RPM OF SELECTED MODELS			RPM
0.00		.125		.250		.375		.500		.625		.750		1.00		CRDA16J8*	CRDA16L11*	CRDA16N17*				
BHP	Sone	BHP	Sone	BHP	Sone	BHP	Sone	BHP	Sone	BHP	Sone	BHP	Sone	BHP	Sone	1/2 HP	1 HP	2 HP				
2439		2321		2178		2018		1854		1621									825			
0.22	8.3	0.24	7.6	0.26	7.2	0.27	6.9	0.28	6.2	0.28	5.9								1160			
3429		3349		3262		3165		3057		2942		2830		2595								
0.60	16.8	0.64	15.8	0.67	15.2	0.69	14.9	0.72	14.4	0.74	14.1	0.76	14.0	0.79	12.2				1750			
5173		5121		5067		5012		4954		4894		4830		4693								
2.08	31	2.12	30	2.17	29	2.22	29	2.26	28	2.31	28	2.35	28	2.43	27							

CRDA18																CFM at Static Pressure			RPM OF SELECTED MODELS		RPM
0.00		.125		.250		.375		.500		.625		.750		1.00		CRDA18J8*	CRDA18L11*				
BHP	Sone	BHP	Sone	BHP	Sone	BHP	Sone	BHP	Sone	BHP	Sone	BHP	Sone	BHP	Sone	1/2 HP	1 HP				
3,095		2,995		2,824		2,666		2,482		2,233		1,915							825		
0.31	11.7	0.33	10.8	0.36	10.5	0.38	9.7	0.40	9.6	0.41	8.9	0.40	8.5						1160		
4,352		4,291		4,208		4,084		3,966		3,856		3,740		3,476							
0.86	23	0.89	22	0.93	21	0.97	21	1.01	21	1.04	21	1.06	19.3	1.10	19.9						

CRDA20																CFM at Static Pressure			RPM OF SELECTED MODEL	RPM
0.00		.125		.250		.375		.500		.625		.750		1.00		CRDA20M11*				
BHP	Sone	BHP	Sone	BHP	Sone	BHP	Sone	BHP	Sone	BHP	Sone	BHP	Sone	BHP	Sone	1-1/2 HP				
5,730		5,621		5,506		5,382		5,255		5,130		5,007		4,754					1160	
1.45	34	1.49	28	1.54	25	1.59	24	1.64	24	1.67	24	1.68	23	1.73	22					

Performance shown is for Type A: free inlet, free outlet. Performance ratings do not include the effects of appurtenances (accessories).  
 The sound ratings shown are loudness values in hemispherical sones at 1.5 m (5 ft) in a hemispherical free field calculated per AMCA Standard 301.  
 Values shown are for Installation Type A: free inlet hemispherical sone levels.  
 \* - These models are not compatible with variable speed control.  
 AMCA Certified Ratings apply to the CRDA Roof Ventilator constant speed fans and not variable speed fans.

## Installation

Most models are shipped fully assembled and ready for installation. Always inspect equipment for transit damage before accepting delivery to assure a valid claim. Special handling and storage procedures are required if unit is to remain idle for a long time prior to installation.

### Placement

All belt-driven units must be accessibly installed for maintenance and servicing of belts, bearings, motors and pulleys. Horizontal operation only is recommended to assure satisfactory damper operation.

### Mounting

Satisfactory operation of roof ventilators requires mounting on adequately designed and constructed roof curbs. Prefabricated curbs for convenience in installation are available from ILG. Install with base of unit horizontal. Provide adequate caulking, flashing or other weatherproofing means.

### Inspection

Check centrifugal wheel for free rotation.  
Check belt for proper tension (CRBCA & CRBA).  
Check bearings for proper and secure locking to drive shaft (CRBA).  
Check motor and fan sheave faces for proper alignment (CRBCA & CRBA).  
Check circuit phase, voltage and wiring connection against that shown on motor nameplate.  
Check direction of fan rotation for proper air flow.  
After one week of operation, check belt for proper tension (CRBCA & CRBA).

## Maintenance

Units should be checked monthly for the first two or three months and periodically thereafter. Units should be cleaned periodically and checked for eroded parts which should be replaced to avoid structural damage and possible failure. Proper lubrication is the most important maintenance requirement. CRBA units should be lubricated as necessary based on usage and operating conditions. "C-Drive" bearings on all CRBCA units are permanently sealed and require **no** lubrication. Motor bearings should be lubricated according to the motor manufacturer's instructions.

### Adjustment of Variable Pitch Pulley and Belt (CRBCA & CRBA)

Variable pitch pulley may be adjusted within catalog RPM range to alter performance without motor overload. Pulley alignment and belt tension should be adjusted if necessary. Inspection every 6 to 12 months is recommended.

## Options & Accessories

### Prefabricated Roof Curbs

Insulated roof curbs with weather-resistant continuous welded construction are available for convenience in installation for both insulated and non-insulated roof decks.

### Special Motors

Two-speed, totally enclosed, energy efficient and explosion-proof motors for hazardous locations may be available for many models. Motor requirements may affect UL Listing.

### Backdraft Dampers

Gravity or motor operated backdraft dampers are available. They are aluminum construction and designed for installation in prefabricated roof curbs.

### Safety Disconnects

Safety disconnects cut power to motor for servicing of unit. A disconnect device is standard on all CRDA units and an option for CRBA and CRBCA units. It may be shipped loose for field installation or factory mounted and wired.

### Protective Coatings

Fan units are not recommended for exhausting air of a corrosive nature. However, special protective coatings are available where units may be exposed to corrosive exterior conditions. Parts requiring painting are processed through the American Coolair five-stage pretreatment system prior to the application of any coatings to insure maximum finish adhesion. These parts use a thermosetting epoxy powder paint with an average thickness of 3 mils and baked at 400°F to a smooth, hard continuous finish. Consult your ILG Industries representative for available coatings.

### Roof Handle

Aluminum handle facilitates removal of roof.

## WARNING



## CAUTION

**DO NOT** INSTALL FAN WITH MOVING PARTS WITHIN 8 FEET OF FLOOR OR GRADE LEVEL WITHOUT A GUARD THAT COMPLIES WITH OSHA REGULATIONS. **DO NOT** USE UNLESS ELECTRICAL WIRING COMPLIES WITH ALL APPLICABLE CODES. **DO NOT** WIRE WITHOUT PROVIDING FOR A POWER SOURCE DISCONNECT AT THE FAN ITSELF. **DO NOT** SERVICE EXCEPT BY A QUALIFIED MAINTENANCE TECHNICIAN AND ONLY AFTER DISCONNECTING THE POWER SOURCE. FAILURE TO OBSERVE THESE PRECAUTIONS CAN RESULT IN SERIOUS INJURY OR DEATH.

To convert air performance (CFM and SP) and power (BHP) to metric units, multiply CFM x .000472 to obtain cubic meters per second (m<sup>3</sup>/s). Multiply SP x 248.36 to obtain pascals (Pa). Multiply BHP x .7457 to obtain kilowatts (kW).

**Example:** 3904 CFM x .000472 = 1.8427 m<sup>3</sup>/s  
0.125 SP x 24.36 = 31.05 Pa  
0.886 BHP x .7457 = 0.661 kW

## CRBCA Specification Checklist

General exhaust units for low to medium air volumes in commercial, institutional and light manufacturing buildings. Centrifugal design with advantages of compact, attractive appearance, quiet operation and performance against higher static pressures. Variable pitch belt drive allows for speed adjustment. Hinged motor bracket with a belt tensioning bolt. Weatherproof heavy duty aluminum housing and motor compartment cover resist corrosion and maintain appearance. Deep-spun, overlapping, one-piece venturi minimizes noise, reduces air turbulence and improves efficiency. "C-Drive" design provides a calculated L10 bearing life in excess of 1,000,000 hours with its unique radial loading elimination design. Aluminum centrifugal wheel is quiet, non-overloading, backward-inclined design and is computer balanced. Standard open drip-proof motor is out of the airstream for protection. The motor's electrical connection terminal board is up for easy and convenient electrical connection and servicing. Positively cooled motor compartment with forced air ventilation system extends motor life. UL Label (UL 705) for general ventilation. Conduit raceway for ease in connecting to power supply. AMCA Seal assures certified rating of air and sound performance. Birdscreen prevents entry of birds or other potentially damaging objects. Heavy duty neoprene isolators eliminate metal-to-metal contact, reducing vibration and sound.

## CRBA Specification Checklist

Units provide general exhaust of low, medium and high air volumes in commercial, institutional and light manufacturing buildings. Centrifugal design has advantages of compact, attractive appearance, quiet operation and performance against higher static pressures. Variable pitch belt drive allows for speed adjustment. Hinged motor bracket with belt tensioning bolt(s). Weatherproof heavy duty aluminum housing and motor compartment cover resist corrosion and maintain appearance. Deep-spun, overlapping, one-piece venturi minimizes noise, reduces air turbulence and improves efficiency. Centrifugal wheel is quiet, non-overloading, backward-inclined design and is computer balanced. Standard open drip-proof motor is out of the airstream for protection. The motor is mounted with the shaft up for convenient access to the variable pitch cast iron motor pulley. Motor compartment is cooled by a forced air ventilation system, extending motor life. UL Label (UL 705) for general ventilation. Conduit raceway allows for ease in connecting to power supply. AMCA Seal assures certified rating of air and sound performance. Birdscreen prevents entry of birds or other potentially damaging objects. Heavy duty neoprene isolators eliminate metal-to-metal contact, reducing vibration and sound. Heavy duty pillow-block bearings with cast iron housing are self-aligning and relubricable.

## CRDA Specification Checklist

General exhaust units for low to medium air volumes in commercial, institutional and light manufacturing buildings. Centrifugal design with advantages of compact, attractive appearance, quiet operation and performance against higher static pressures. Spun aluminum housing for durable weather protection and attractive appearance. Direct-drive advantages of minimal maintenance and operating costs. Deep-spun, overlapping, one piece venturi minimizes noise, reduces air turbulence and improves efficiency. Aluminum centrifugal wheel is quiet, non-overloading, backward-inclined design and is computer balanced. Standard open motor is out of the airstream for protection. The motor's electrical connection terminal board is up for easy and convenient electrical connection and servicing. Positively cooled motor compartment with forced air ventilation system extends motor life. UL Label (UL 705) for general ventilation. Safety disconnect device enables cut-off of power to unit for servicing. Birdscreen prevents entry of birds or other potentially damaging objects. Factory run and tested prior to shipment for dependable operation. AMCA Seal assures certified rating of air and sound performance.

## Limited Warranty

In the sale of its products, American Coolair Corporation agrees to correct, by repairs or replacement, any defects in workmanship or material that may develop under proper and normal use during the period of one year from the date of shipment from the factory. Any product or part proving, upon American Coolair's examination, to be defective during limited warranty period will be repaired or replaced, at American Coolair's option, f.o.b. factory, without charge.

Deterioration or wear caused by chemicals, abrasive action or excessive heat shall not constitute defects.

Motors are guaranteed only to the extent of the manufacturer's warranty.

American Coolair's limited warranty does not apply to any of its products or parts that have been subject to accidental damage, misuse by the user, unauthorized alterations, improper installation or electrical wiring, or lack of proper lubrication or other service requirements as established by American Coolair.

Repairs or replacements provided under the above terms shall constitute fulfillment of all American Coolair's obligations with respect to limited warranty.

THE LIMITED WARRANTY STATED HEREIN IS IN LIEU OF ALL OTHER WARRANTIES, EXPRESS, STATUTORY OR IMPLIED, INCLUDING WITHOUT LIMITATION THAT OF MERCHANTABILITY AND FITNESS.

NO LIABILITY FOR REINSTALLATION COST OR FOR ANY SPECIAL, INDIRECT OR CONSEQUENTIAL DAMAGES OF ANY NATURE IS ASSUMED OR SHALL BE IMPOSED UPON AMERICAN COOLAIR.



**AMERICAN COOLAIR CORPORATION**

REPRESENTED BY:          
---

JACKSONVILLE, FLORIDA 32203-2300 ~ P.O. BOX 2300 ~ (904) 389 3646 ~ FAX (904) 387 3449 ~ E-MAIL - info@coolair.com ~ WEBSITE - coolair.com  
VANE AXIAL FANS ~ TUBE AXIAL FANS ~ PROPELLER FANS ~ POWER ROOF VENTILATORS ~ CENTRIFUGAL VENTILATORS  
MEMBER OF AMCA

Form No. 725-15-4 (December, 2008)

